

RESEARCH NEWS

01 | 2014 ||

1 Treating chronic kidney disease using clay minerals

Clay has healing powers. This natural product is destined to help treat chronic kidney disease: a well-tolerated agent based on clay minerals lowers patients' excessive phosphate levels.

2 Car manufacturing – fast track towards mass production

New models of automobiles are initially manufactured in a pilot production run. A new procedure now makes it possible to transfer the parameters applied there directly to serial production.

3 Warping images using your PC graphics card

By projecting images onto contoured surfaces you get a virtual experience that puts you at the center of the action. Now, a quick and easy calibration technique could help the concept find a wider application beyond the planetarium.

4 Ultra-thin tool heating for injection molding

In future, thin-film heating will allow plastic parts to be produced with greatly improved surface quality. Researchers have also found a way to make the whole process more energy efficient.

5 Hydrocephalus: sensors monitor cerebral pressure

If the pressure in a patient's brain is too high, physicians implant a system in the head that regulates the pressure. A sensor can now measure and individually adjust brain pressure. The sensor system is approved for use as a long-term implant.

6 Faster testing of new pharmaceuticals

To improve medical treatment, researchers test new drug ingredients on biological cells. By combining two microscopy techniques, the time required for testing can be reduced by 50 to 80 percent. And far fewer measurements are needed.

7 Click away the snow

The control center at the Cologne Bonn Airport coordinates a number of actors during winter services. The new software upgrades the airport's central control of winter service activities. Now, one click is enough in order to respond to weather changes.

8 Newsflash

The Fraunhofer-Gesellschaft is the leading organization for applied research in Europe. Its research activities are conducted by 66 institutes and independent research units at locations throughout Germany. The Fraunhofer-Gesellschaft employs a staff of more than 22,000, who work with an annual research budget totaling 1.9 billion euros. Roughly two thirds of this sum is generated through contract research on behalf of industry and publicly funded research projects. Branches in the USA and Asia serve to promote international cooperation.

Editorial Notes:

RESEARCH NEWS | Frequency: monthly | ISSN 09 48 - 83 83 | Published by Fraunhofer-Gesellschaft | Corporate Communications | Hansastraße 27 | 80686 München | Phone +49 89 1205-1333 | presse@zv.fraunhofer.de | Editorial Staff: Beate Koch, Britta Widmann, Tobias Steinhäuser, Janine van Ackeren | Reprints free of charge. We encourage you to favor the online version and newsletter via www.fraunhofer.de/fhg/EN/press This bulletin is also available in German as FORSCHUNG KOMPAKT.

Treating chronic kidney disease using clay minerals

RESEARCH NEWS

01 | 2014 || Topic 1

Miss M. spends around 15 hours a week in hospital. Her renal functions are limited, and her kidneys are no longer able to filter toxins from her blood. She is a dialysis patient, forced to rely on this artificial blood purification treatment that, although essential, greatly impairs her quality of life. She has to make three trips a week to the dialysis clinic and going away for longer than a few days is almost out of the question. And Miss M. is no exception: In Germany alone, over six million people suffer from some form of chronic renal disease. Around 70,000 depend on dialysis and they are joined by some 15,000 new dialysis patients every year. Poor diet and an aging population are contributing to the dramatic rise in chronic renal disease worldwide, with high blood pressure and diabetes the most significant risk factors related to renal failure.

When suffering from renal failure, the body is unable to filter out phosphates in sufficient quantities, and the resulting excess is then absorbed into the blood. This causes a build-up of calcium-phosphate deposits in the blood vessels, which can over an extended period lead to arteriosclerotic heart disease and premature death. Compared to people with healthy kidneys, those with compromised renal function are at least ten times more likely to suffer a heart attack or stroke. To counteract this increased risk, people suffering from chronic renal insufficiency are required to take phosphate binders with meals. In the stomach and intestines, these medications bind to phosphates from food so that they can be excreted undigested instead of being absorbed into the blood. The problem is that existing medications, such as calcium and aluminum salts, cause serious side-effects including constipation, hypercalcemia (an elevated level of calcium in the blood), and neurologic disorders.

Gentle alternatives to pharmaceutical treatments

But hope is in sight for sufferers of chronic renal disease. Scientists from the Fraunhofer Institute for Cell Therapy and Immunology IZI in Rostock teamed up with FIM Biotech GmbH to develop an effective therapeutic agent that patients can tolerate well. Formed by marine deposits of volcanic ash 60 billion years ago, clay minerals found in the Friedland area of north-east Germany provide the basis for the new agent. The clay first has to be processed before being refined using a special technical process.

In a series of laboratory trials and cell culture experiments, the cooperation partners were able to prove the high phosphate-binding capacity and tolerance rate of the clay minerals. "The phosphate binder obtained from pure mineralogical raw materials is just as effective as traditional pharmaceutical binders. It can lower renal patients' elevated phosphate levels. Our tests using animal models show that, unlike standard medications, our binder causes only mild side-effects," says Prof. Dr. Steffen Mitzner, head of the Working Group on Extracorporeal Immunomodulation in Rostock and Professor of Nephrology at the city's university. The scientists believe that their refined natural raw

material could also be used in the treatment of inflammatory bowel disease. Another animal model trial is currently underway to determine the scope of using clay minerals to help heal artificially induced bowel inflammation.

The Fraunhofer scientists and FIM Biotech GmbH have filed a patent application for their agent and refining technique. The animal trials are scheduled for completion by the end of 2013, and the scientists expect to be able to start passing on the benefits of the new agent to the first patients when clinical trials begin in early 2014.



Based on naturally occurring Friedländer clay, shown here in its raw state: A new agent in the treatment of chronic kidney disease. (© FIM Biotech GmbH) | Picture in color and printing quality: www.fraunhofer.de/press

Car manufacturing – fast track towards mass production

RESEARCH NEWS

01 | 2014 || Topic 2

More and more varieties of automotive models are penetrating the market, product lifespans are getting shorter, and energy costs are soaring. Above all, the protracted ramp-up time in auto body assembly are causing problems for manufacturers: They have to adapt production systems to each of the new parts and assemblies, which is highly time-intensive.

In order to put together individual elements, such as a door or a side panel, the manufacturers clamp the individual parts into model-specific clamping devices and weld them together. In doing so, precision is absolutely critical. “The not yet completely welded door is an unstable structure - if you adjust it at one point, then it deflects a different one. The employees have to calibrate the devices exactly, in order to set the part,” says Marco Breitfeld of the Fraunhofer Institute for Machine Tools and Forming Technology IWU in Chemnitz. It can last several months for each new vehicle model until the system is set optimally. The pilot production run does not help in this regard. Because the fixtures used there have nothing in common with the ones used later.

Dramatically reducing ramp-up times

The new device engineered at IWU allows already determined parameters to be directly transferred to serial production. “We hope to be able to reduce the start-up times by up to 50 percent,” Breitfeld indicates. The procedure used is called “try-out,” and is already applied to the reshaping process at the pressing plant. Special try-out presses determine, for example, the regulating variables for quality production beyond the serial process already – without interrupting the production process. The presses simulate the process parameters and the production environment of the regular system. Now, the scientists have transferred the process to car body assembly. “We are really breaking new ground here, and have transferred the principle of the presses to the clamping devices,” the researcher says.

These contain four functional elements that are assembled similarly to a construction kit. With height modules, the console heights can be adjusted flexibly; the angle modules determine the angle of the clamping elements. Shim modules, specific surfaces of varying thickness, are used for fine-tuning. Workers have a maximum of ten millimeters of leeway in any direction. Through the modulus of rigidity, the researchers simulate how rigid the device would be if it were made of steel, aluminum or synthetic material.

The IWU can also unlock the potential for lighter weight using this process. Not for the chassis, but instead for the devices and parts that the carmaker needs in order to produce. The researchers are using the try-out device as an experimental tool. They can also simulate the rigidity of the individual components and clamping elements. They test the limits of the system and determine how much weight can be saved without

compromising the stability of the construction. "When a model is changed, the manufacturers often exchange entire systems. For example, this could weigh up to two-and-a-half tons for a side panel. A flexible production is impossible with such large systems," explains the IWU scientist. Development of the try-out fixture is complete. Researchers are going to offer the corresponding services still this year.

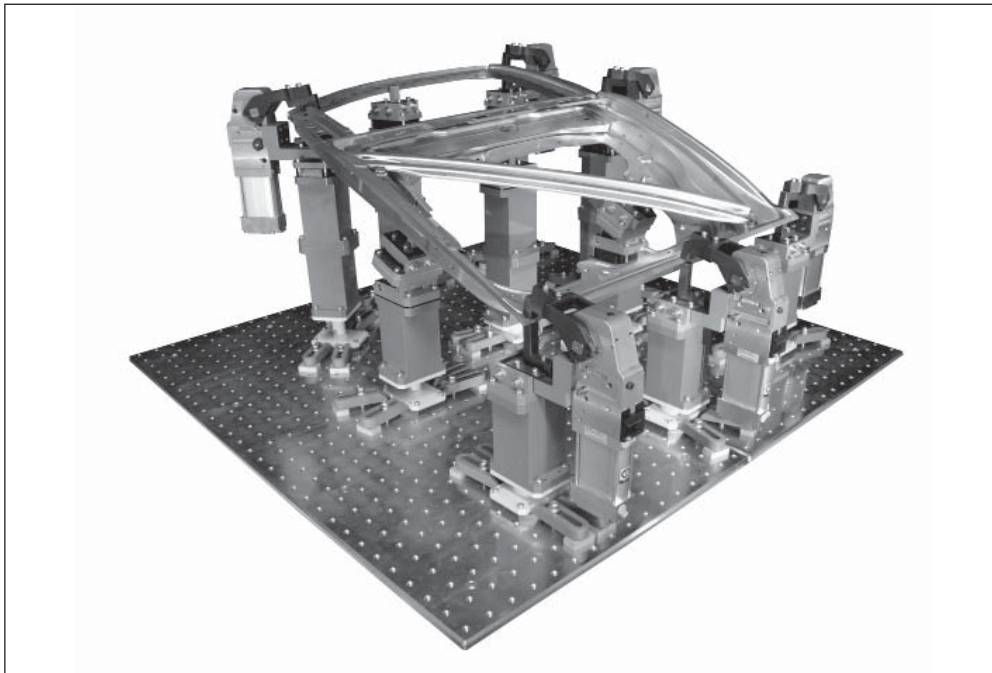

Clamping elements attach a metal part in car body assembly. A new device takes over the parameters set in the pilot production run, and makes the production process faster and more flexible. (© Fraunhofer IWU) | Picture in color and printing quality: www.fraunhofer.de/press

Warping images using your PC graphics card

RESEARCH NEWS

01 | 2014 || Topic 3

It's almost as if you were weightless. You can reach out and touch the Big Dipper and all around you are multitudes of twinkling stars. The glowing band of the Milky Way is clear in the sky, leaving you with the impression of actually being enveloped within it. In short, the perfect illusion – numerous projectors broadcasting a recreated version of the actual night sky onto the huge dome of the planetarium. The biggest of these domed projection screens measure over 20 meters in diameter. Now, scientists from the Fraunhofer Institute for Open Communication Systems FOKUS in Berlin have joined forces with graphics card manufacturer NVIDIA to integrate the technology required to project images of this type using a standard PC graphics card. "Desktop warping" allows any Windows desktop display to be projected onto curved screens – just like in a planetarium.

But how exactly do you go about "warping" screens? Manuel Schiewe, a FOKUS researcher who has dedicated a lot of time to the topic, is on hand to provide some answers. To get an even picture on a curved screen, each of the projectors must be precisely calibrated with one another. Each of them projects a part of the image, parts which together form the whole. "It's a bit like a puzzle. Every piece has to slot in exactly with the others to get the right picture," explains Schiewe. Projectors must be set up so that the images they project are of an equal brightness and suitable for a curved surface. This requires Schiewe to recalibrate the images, which were originally intended for a flat screen.

Initially, the only way this could be done was to calibrate manually. "As soon as the position of the projectors moved even slightly, we had to step in and make manual adjustments," recalls Schiewe. The solution came from Fraunhofer FOKUS's laboratories in Berlin, where researchers developed a piece of software that automatically calibrates images to match the projection screen. To do this, cameras capture test images generated by the projectors. The software then uses image processing algorithms to calculate the current calibration of the images on the projection screen. It then has all the information it needs to make automatic corrections to the calibration and brightness of the images. "Today, planetariums, theme parks and simulators use the 'Projector auto-alignment' tool to guarantee an even picture on large contoured surfaces," says Schiewe.

Integrating the software into graphics card drivers

Until now, this technology has been available only in combination with Fraunhofer FOKUS's media player, which is designed for specific media formats such as films, images, text or graphics. To be able to project any type of content calls for special software and hardware tools, connected between the graphics card and the projector. Time and cost escalate when users have to connect extra devices, and this also results in a delay

in video display. "That is why we took the decision to integrate the automatic calibration software straight into graphics cards' drivers. This way, the whole Windows desktop – and any Windows programs – automatically adjust to curved projection screens. Companies can easily make the most of being able to project onto any surface using their on-board graphics card. Their staff have more ways to communicate with one another, and can do so in a targeted manner. It's easier, too, to exchange and present content more effectively – even over long distances," explains Schiewe.

One example is remote maintenance of oil platforms. Ever since the "Deep Water Horizon" accident, engineers have increasingly been monitoring these platforms off-shore, with all the most important data and developments from out at sea flowing into land-based control rooms. Modern media technologies such as "Desktop warping" display information about the platform in a way that immerses the controllers and, in a virtual sense, puts them at the center of the action.

<http://www.fokus.fraunhofer.de/de/viscom/index.html>

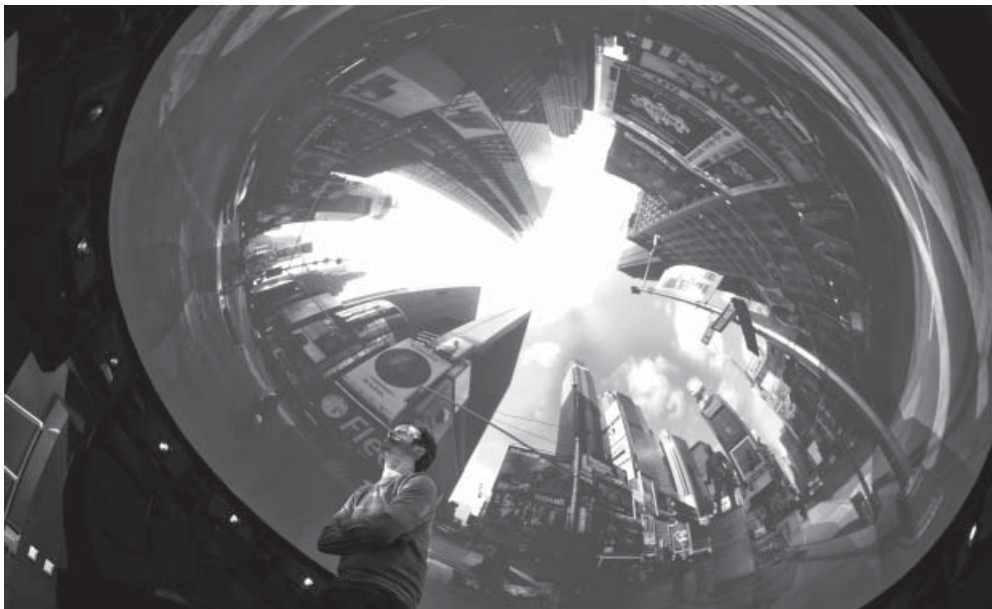

Using modern domed projection screens to take a virtual stroll around New York's Times Square. Now the technology has also been integrated directly in desktops' graphics card drivers. (© Fraunhofer FOKUS / Matthias Heyde) | Picture in color and printing quality: www.fraunhofer.de/press

Ultra-thin tool heating for injection molding

RESEARCH NEWS

01 | 2014 || Topic 4

If you have ever tried to make waffles then you are bound to be familiar with the following problem: You only get good waffles if the iron is heated to the correct temperature. The same principle applies to the manufacture of plastics parts, such as displays, facings, covers and instrument panels, using injection molding techniques. A liquid plastic melt is injected into a steel forming tool which is heated just like a waffle iron. The point is to produce a perfect cast of the tool's surface, which may be smooth like a mirror or feature a functional structure. Using injection molding to realize the desired structural and functional surface qualities of plastic parts is intended as a one-step process without the need for any extensive finishing work. The process also has to be economic and energy efficient.

To manufacture plastic parts with high-end surfaces, the entire forming tool is heated to around 110 degrees Celsius using a technique known as variothermic tempering. Thermoplastic materials such as polycarbonate are processed at similar temperatures. In order to get the finished plastic part out without damaging it, the mold must be cooled by around 20 to 30 degrees Celsius. This has to be done for every production cycle before the whole process can begin again, which "eats up a considerable amount of energy," explains Alexander Fromm from the Fraunhofer Institute for Mechanics of Materials IWM in Freiburg.

Working to improve the situation, Fromm and his colleagues teamed up with the Kunststoff-Zentrum in Leipzig to develop a new kind of tempering technique that, depending on the product, is up to 90 percent more energy efficient than other techniques used to date. The trick is to avoid having to heat up the entire tool; these can weigh half a ton or even more depending on the plastic part being produced. All that is heated now is the surface of the tool that actually comes into contact with the plastic melt.

A micrometer-thin layer

This is possible thanks to thin-film heating. Researchers coat the wall of the forming tool using a vacuum-based coating technique known as sputtering. Imagine a game of pool in which the balls are base-material atoms – in this case from the thin film. Hitting them with energy-rich ions sends them ricocheting around the vacuum chamber. The sputtered material is deposited onto the surface of the forming tool in layers only a few micrometers thick (1 micrometer equals one thousandth of a millimeter). To put this into perspective, a human hair is approximately 80 micrometers thick. Not only can this extremely thin coating be used to heat the forming tool surface to the desired temperature, but it is also capable of withstanding the thermodynamic stresses that occur during injection molding.

Electrical insulation is provided by a ceramic layer that shields the conductive heating layer from the steel tool underneath. The layer that actually gets heated is made of a specially designed conductive hard material. In this case, the challenge of sputtering lies not only in producing a perfect insulating layer so as to avoid any short circuits, but also in integrating a sensor into the thin-film heating layer. A sensor placed here can measure the temperature of the tool wall and be used to regulate the manufacturing process.

To achieve this, the researchers set about integrating incredibly fine thermocouples, made from nickel or nickel-chrome alloy and each just a few hundred nanometers thick. Thermocouples can be produced using thin-film technology and incorporated into the insulation layer. Due to their extremely low mass, thermocouples react incredibly fast to temperature changes and make it possible to directly measure the temperature of the tool wall. Through a series of laboratory experiments, the researchers were able to demonstrate that thin-film heating can be used to achieve the desired tool wall temperature very quickly indeed. The researchers are now looking for industry partners to help prepare the process for use in series manufacture.

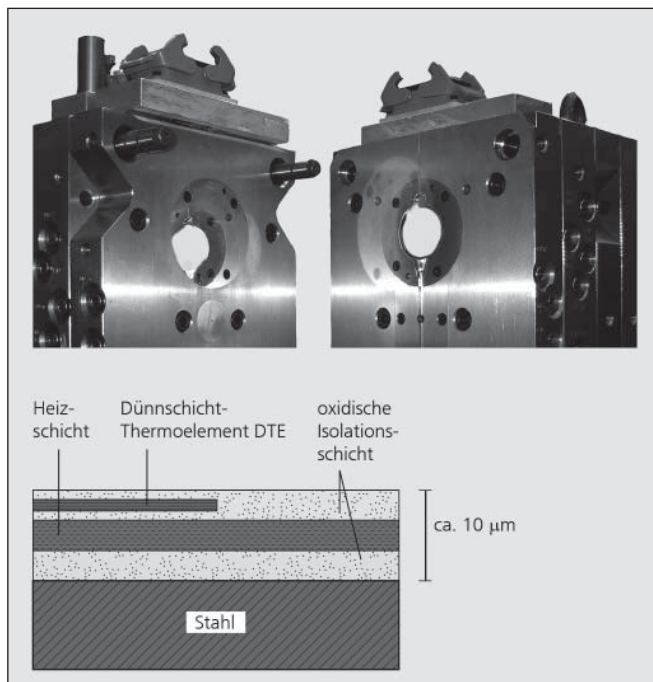

More cost-efficient plastic components with improved surface quality: This injection-molding tool is equipped with thin-film tempering coatings (round area on each half of the opened tool). (© Fraunhofer IWM) | Picture in color and printing quality: www.fraunhofer.de/press

Hydrocephalus: sensors monitor cerebral pressure

RESEARCH NEWS

01 | 2014 || Topic 5

Urinary incontinence, a shuffling gait, and deteriorating reasoning skills are all indicators pointing to a Parkinsonian or Alzheimer type disease. An equally plausible explanation is hydrocephalus, commonly known as “water on the brain.” With this diagnosis, the brain produces either too much cerebral fluid, or it cannot “drain off” these fluids with adequate sufficiency. The consequence: Pressure in the brain rises sharply, resulting in damage. A shunt system – a kind of silicon tube that physicians implant into the patient’s brain, provides relief. It draws off superfluous fluid from there, for example, into the abdominal cavity. The heart of this shunt system is a valve: If the pressure increases above a threshold value, then the valve opens; if it declines again, then the valve closes.

In rare cases, over-drainage may occur. The cerebral pressure lowers too much, the cerebral ventricles are virtually squeezed out. Until now, physicians could only detect and verify such over-drainage through elaborate and costly computer and magnetic resonance tomography.

Cerebral pressure measurable anytime

With a new kind of sensor, things are different: If it is implanted into the patient’s brain with the shunt system, the physicians could read out brain pressure using a hand-held meter: within seconds, anytime and without complex investigation. Researchers at the Fraunhofer Institute for Microelectronic Circuits and Systems IMS in Duisburg, working jointly with Christoph Miethke GmbH and Aesculap AG, engineered these sensors.

If the patient complains of discomfort, then the physician merely needs to place the handheld meter outside, on the patient’s head. The device sends magnetic radio waves and supplies the sensor in the shunt with power- the implant is “awakened,” measures temperature and pressure in the cerebral fluid, and transmits these data back to the handheld device. If the pressure on the outside of the desired area, the physician can set the valve on the shunt system from the outside as needed, and individually adjusted to the patient. “The sensor is an active implant, which also takes over measurement functions, in contrast to a stent or a tooth implant,” says Michael Görtz, head of pressure sensor technology at IMS.

The implant must be biocompatible; the body cannot reject it. Researchers had to ensure that the body also would not attack the implant. “The defense response behaves just like an aggressive medium, that would even dilute the silicon of the electronics over the course of time,” explains Görtz. Miethke therefore completely encases the implant into a thin metal casing. “We can still supply it with power from the outside through the metal casing, measure cerebral pressure through the housing and transmit the recorded data outside, through the metal to the reader,” Görtz explains. To do so,

the correct metal had to be found. The coating may not be thicker than the walls of a soft drink can – in other words, much thinner than one millimeter. The researchers even developed the handheld reading device, together with the electronics, through which it communicates with the sensor.

The sensor is ready for serial production, and was already approved by Miethke. The company has already initiated the market launch of the system. “The sensor sets the basis for the further development through to theranostic implants – a neologism derived from the words “therapy” and “diagnostic.” In a few years, the sensor could then not only record cerebral pressure and develop a diagnosis on the basis of this, but also properly adjust the pressure independently, immediately on its own and thus, take over the therapy process,” says Görtz.

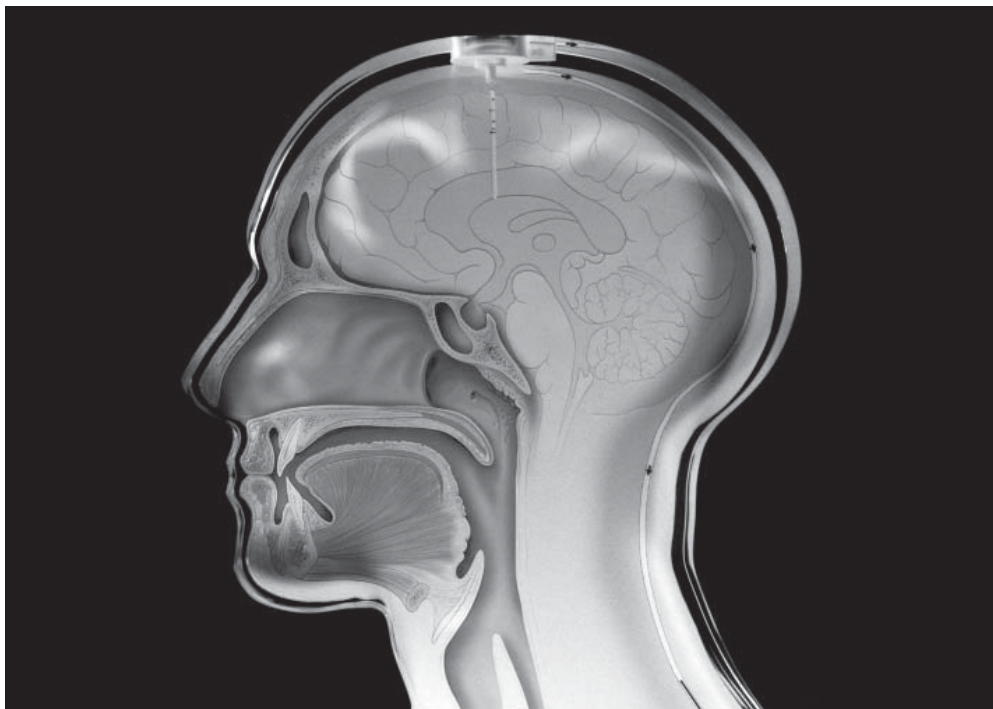

Physicians can measure cerebral pressure with the aid of implanted monitoring sensor. They merely place a hand-held reading device on the head of the patient. (© Patrick J. Lynch / Fraunhofer IMS) | Picture in color and printing quality: www.fraunhofer.de/press

Faster testing of new pharmaceuticals

When developing new medications, biologists and pharmacologists test different active ingredients and chemical compounds. The main purpose is to find out how biological cells react to these substances. To do so, researchers often use a fluorescence microscope that produces digital, holographic images, i.e. computer-generated holograms in which the cells being studied can be viewed in three dimensions. The hologram is first created as an optical image, which is then digitized for recording and analysis on the computer. The computer calculates the data needed to display the three-dimensional image of the cells. This method has several advantages. The researchers don't have to use markers to make the cells visible. They can examine the cells without touching them. And the cells can be characterized *in vivo* – scientists refer to this as *in vivo* testing.

To obtain precise and reliable answers to the question of how the cells react to chemical substances, each cell must be placed in an individual, tiny hollow (well) on a microfluidic chip, i.e. one cell per well. This ensures that the cells are not influenced by the presence of other cells. Another requirement is that the cells must be of the same size, so that their reactions to the active agent can be compared. The problem is that it is difficult to transfer single cells to the tiny wells. Often, the researchers pour them in together with the nutrient solution in which they were grown. This can have two unwanted consequences: firstly that several cells occupy the same well and secondly that the cells are of all different sizes. It can even happen that cells swim out of the wells during the test. The researchers have to take all these factors into account by employing statistical averaging. In other words they have to carry out innumerable measurements and test large numbers of cells in order to obtain a scientifically accurate result – an undertaking that can be extremely tedious and time-consuming.

Combination of digital holographic microscopy and optical tweezers

Researchers at the Fraunhofer Institute for Production Technology IPT in Aachen have found a solution to this problem. "It combines digital holographic microscopy with the use of optical tweezers," reveals IPT group manager Stephan Stürwald. Optical tweezers are a special instrument that uses the force of a focused laser beam to trap and move microscopic objects. This tool enables the researchers to pick up selected cells, transfer them to individual wells of a microarray, and keep them trapped there. "By combining these two instruments, we can save between 50 and 80 percent of the time normally needed for such work, depending on the type of cell and the test method employed. That's mainly because we don't have to carry out so many repeated measurements," explains Stürwald. The system is very easy to use, and the optical tweezers can also be controlled via the touchscreen of a tablet PC.

The combination of these two techniques not only simplifies current test procedures

but also allows new tests to be developed. For instance, it is possible to position cells at a defined distance from one another, thus creating different patterns. In this way, the scientists will be able to observe cell interactions, because the spacing between them is identical and fixed. One possible application is in the study of apoptosis, or sudden cell death. When a cell dies by apoptosis, it excretes substances that affect the behavior of other cells around it. But within what radius? Researchers will now be able to directly answer this question. The new system will also enable them to use the laser to selectively destroy cells that are unsuitable for testing. A prototype of the system has already been built. It consists of two modules: the optical tweezers and the digital holographic microscope. The researchers have successfully carried out initial tests using the new system.

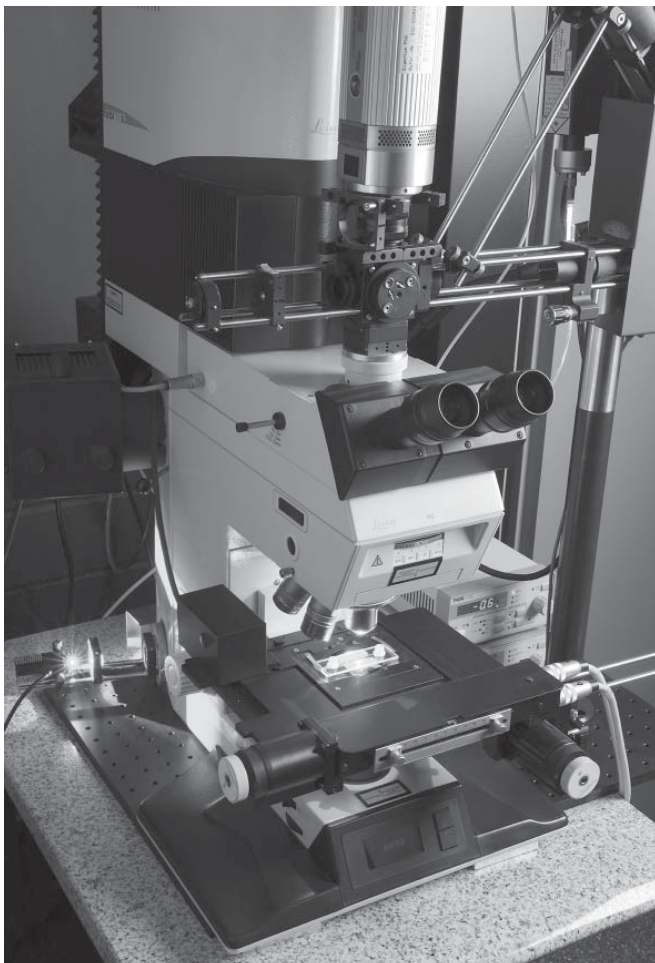

This system enables researchers to study cell interactions. The prototype consists of two integrated modules: the optical tweezers and the digital holographic microscope. (© Fraunhofer IPT) | Picture in color and printing quality: www.fraunhofer.de/press

Click away the snow

The airport sprayer looks like an airplane. Instead of wings, yellow metal arms protrude to the left and right from the snow plough. With these, it distributes de-icing fluid on the runways of the Cologne Bonn Airport for up to a width of 45 meters. Alexandra Cahn is the Winter Services Coordinator at the second largest airport in North Rhine-Westphalia, making sure that in spite of ice and snow, 190 take-offs and landings can operate seamlessly every day. "One click is all it takes for me to know whether there is still enough de-icing fluid in the tank," explains Cahn, pointing with her finger to the small tank-icon on the right side of the screen. In the middle, the entire airport area shows up in front of her from a bird's eye-perspective. She sees runways, terminals and taxiways – the lanes for the airplanes – in principle everything that exists on the 130 hectare-sized area. Cahn can change the perspective that she uses to look at the airport grounds from up above. When she zooms into the screen, the information becomes denser.

The application retrieves the data from the depths of the airport IT system – from servers and databases. Since the beginning of November, the airport has been running "Intelsys," the graphical situational awareness system from the Fraunhofer Institute for Communication, Information Processing and Ergonomics FKIE in Wachtberg. The software gathers all the relevant data for winter service in a central database, and processes the incoming flow of data arriving each day. Among other things, these data are recorded by data measurement vehicles that check how slick the runways are, and by temperature probes that indicate how cold it is outside on the runways.

Winter service can be planned predictively

The system knows current weather information, knows what the condition of the snow ploughs is, and has insight into the de-icing work on the airfields. "Winter service can be planned predictively. We have programmed the software in such a way that it automatically warns employees of problems, for example, if the parking positions needed for arriving airplanes have not yet been cleared of ice and snow," Dr. Michael Wunder of FKIE explains. He sits with his team just 50 kilometers south of the airport. The software program detects critical situations automatically – for example, temperatures on the runways are steadily dropping – and offers recommendations for problem resolution.

"Winter service has to react quickly to short-term changes in weather. The smallest delays in the flight schedule cost the airlines a lot of money. With the new situational awareness system, we can access all the necessary data within a few seconds, and introduce preventative measures. We prevent delays and deploy our resources optimally," says Cahn, and clicks on one of the runways on her screen. With a few entries, she advises her colleagues about a interruption to operations on the runway so that the

snow ploughs can provide their services. At the same time, a message is automatically dispatched to all participating offices.

If the software passes the practice phase during winter service, then additional functions will follow. The foundations for this have been laid at FKIE. "The software is capable of gradually taking over other tasks. Among other things, a rules engine has been implemented that lets us flexibly adjust 'Intelsys' to the airport's business processes," says Dr. Christopher Schlick, deputy director of the institute. Cenk Özöztürk, head of the traffic and operations division at the Cologne/Bonn Airport, is pleased with the excellent collaboration between his employees and Fraunhofer FKIE. "With close coordination, the pilot system could be developed within a year. We want to continue this successful concept. Our goal is to control all operating processes from one system."

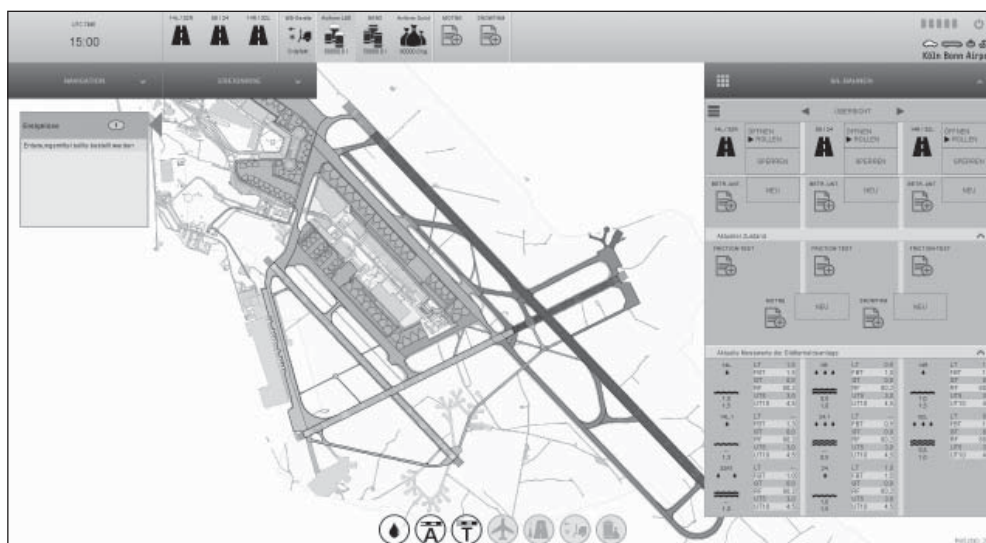

Intelsys is optimized for coordinating in winter service at the Cologne Bonn Airport. A summary of the most important resources and documents (top), instructions on the need for action (left), and the central map provide a visualization of the relevant information for winter service. Modular applications (right) display detailed information on the data and allow the input of changed or new data by users. (© Fraunhofer FKIE) | Picture in color and printing quality: www.fraunhofer.de/press

Letter inspection with terahertz waves

Does that incoming postal dispatch hold merely a harmless letter – or a bomb? Does it possibly contain drugs? T-COGNITION, the terahertz spectrometer helps to swiftly clear-up the question. This analytical device reliably identifies explosives and narcotics in mail pieces, and is primarily suited for use at embassies, public offices and correctional facilities. Letters can be pushed through an input lid into the spectrometer. These are then exposed on the inside to terahertz waves. Detectors collect the reflected and transmitted waves, and compare the spectra with those on a database. Within a few seconds, the data points light up either red or green on the screen of the device – depending on whether any hazardous substances were detected or not. The use of the technology has multiple advantages: Terahertz waves that lie within the electromagnetic spectrum between infrared and microwave are not dangerous, penetrate packaging materials and produce – depending on what kind of materials they hit – characteristic spectra that can be swiftly analyzed with the aid of intelligent software.

T-COGNITION is the result of a research collaboration between the Fraunhofer Institute for Physical Measurement Techniques IPM in Kaiserslautern and the Kassel-based Hübner GmbH Co. KG that has since brought the Terahertz spectrometer on the market. The antennas on the inside of the compact device (60 x 72 x 73 centimeters) were engineered jointly by researchers at IPM and the Carnot Institute IEMN (Institut d'Electronique, Microélectronique et de Nanotechnologies) in Lille.

Fraunhofer Institute for Physical Measurement Techniques IPM

Erwin-Schrödinger-Straße / Geb. 56 | 67663 Kaiserslautern | www.ipm.fraunhofer.de

Contact: Dr. Joachim Jonuscheit | Phone +49 631 205-5107 | joachim.jonuscheit@ipm.fraunhofer.de

Press: Holger Kock | Phone +49 761 8857-129 | holger.kock@ipm.fraunhofer.de

Transporting living cells safely and securely

Scientists often have to exchange cell cultures with colleagues at other institutions, with their partners in industry or with customers. Frequently, the material is transported in a frozen state. Yet when freezing it (which may take several hours), ice crystals form that could inflict irreparable damage to the cells. But even when eventually thawed, there is still the risk that the cells will die off. Then a new cell culture has to be assembled, before the researchers can begin the scheduled experiments and analyses – a good one to two weeks later.

Researchers at the Fraunhofer Research Institution for Marine Biotechnology (EMB) in Lübeck have constructed an autonomous transportation box with which living cells can be transported in a controlled manner, safely and securely and under optimal culture conditions – such as at 37 degrees (Celsius) and with a carbon dioxide (CO₂) content of

RESEARCH NEWS

01 | 2014 || Newsflash

5 percent, for up to 48 hours long. Conventional market cell incubators are not suited for this purpose; because of their dimensions (in cubic meters), they are too heavy and too cumbersome. The mini-incubator (patent pending) is lightweight and no bigger than a parcel box. An internal Lithium Iron battery operates the electronically regulated heating and the CO₂ supply. Integrated sensors monitor and store these parameters that are variably adjustable as well. The built-in CO₂ cartouche can be re-filled from the outside. The researchers have completed their scientific work; the cell transport box is now ready for serial production.

Fraunhofer Research Institution for Marine Biotechnology EMB

Paul-Ehrlich-Straße 1-3 | 23562 Lübeck | www.emb.fraunhofer.de

Contact: Dr. Hans-Peter Spengler | Phone +49 451 384448-61 | hans-peter.spengler@emb.fraunhofer.de

Contact: Dr. Daniel H. Rapoport | Phone +49 451 384448-13 | daniel.rapoport@emb.fraunhofer.de

Press: Dr. Sandra Danner | Phone +49 451 384448-14 | sandra.danner@emb.fraunhofer.de

Online software analyzes sustainability of cities

Plants grow prolifically, creeping upward on the building façades of Singapore; remote heat is flowing through the buildings of Copenhagen – a number of major cities are working on their sustainability. Researchers from twelve Fraunhofer institutes have identified six cities that can do this particularly well: Freiburg, Singapore, Copenhagen, Tokyo, New York and Berlin. The teams identified concrete projects, travelled to the respective cities, analyzed what worked especially well, and derived over 80 fields of action. These include, for example, issues about the organization and structure of the city, or afterwards, how the politics is configured there. This also gave rise to a model for sustainability. Using the online-based tool, cities and communities themselves can analyze what constitutes their sustainability, and working together with researchers, develop concrete solutions for their specific needs. For example, they obtain information about how their city acts in terms of sustainability, and which actions work well, which do not, and why this is so.

For project members, a streamlined version of the program is ready: For this purpose, the researchers – under the aegis of the Fraunhofer Institute for Industrial Engineering IAO in Stuttgart – categorized and prioritized the fields of action, and summarized the most important ones. Scientists are offering the complete software tool to interested municipalities under the joint program.

Fraunhofer Institute for Industrial Engineering IAO

Nobelstraße 12 | 70569 Stuttgart | www.iao.fraunhofer.de

Contact: Alanus von Radecki | Phone +49 711 970-2169 | alanus.radecki@iao.fraunhofer.de

Press: Juliane Segedi | Phone +49 711 970-2343 | juliane.segedi@iao.fraunhofer.de
