

RESEARCH NEWS

11 | 2015 ||

1 Preventing dental implant infections

One million dental implants are inserted every year in Germany, and often they need to be replaced due to issues such as tissue infections caused by bacteria. In the future, these infections will be prevented thanks to a new plasma implant coating that kills pathogens using silver ions.

2 Economic LED recycling

Light emitting diodes are used in a great number of products like televisions and lamps or luminaires. Moreover they are penetrating the automotive lighting market to an ever greater degree. Nevertheless, there are no suitable recycling processes available today for these items. Researchers have developed a method to mechanically separate LEDs.

3 Solar vehicle charging at home

Owners of home photovoltaic systems will soon be able to make their households even more sustainable, because PV power is also suitable for charging personal electronic vehicles. A home energy management system created by Fraunhofer researchers incorporates electric vehicles into the household energy network and creates charging itineraries.

4 The navigation app for buildings

In large buildings, you can lose your orientation. Fraunhofer researchers have developed an Android app that navigates through passages, corridors, rooms and floors to the desired destination. They use WLAN to help with location. The technology can be customized and integrated into other applications.

5 The helping hand in the operation room

Surgeons have their hands full in the operating room: Among other things, clamps have to be set and tools have to be held. Until now, surgical assistants have been responsible for these tasks. In the future, a metal hand that can be controlled by gestures and speech could take some of the weight off of the doctors' shoulders.

6 Simulating technical textiles perfectly

Compression bandages, protective jackets and car seat covers have to meet various requirements. Simulations help to improve such technical textiles for their specific application. Fraunhofer researchers are analyzing structures and yarns as well as the contacts between the individual yarns.

The Fraunhofer-Gesellschaft is the leading organization for applied research in Europe. Its research activities are conducted by 66 Fraunhofer Institutes and research units at over 40 different locations throughout Germany. The Fraunhofer-Gesellschaft employs a staff of around 24,000, who work with an annual research budget totaling 2 billion euros. About 70 percent of this sum is generated through contract research on behalf of industry and publicly funded research projects. Branches in the Americas and Asia serve to promote international cooperation.

Editorial Notes:

RESEARCH NEWS | Frequency: monthly | ISSN 09 48 - 83 83 | Published by Fraunhofer-Gesellschaft | Communications | HansasträÙe 27 | 80686 München | Phone +49 89 1205-1333 | presse@zv.fraunhofer.de | Editorial Staff: Beate Koch, Britta Widmann, Janine van Ackeren, Tobias Steinhäuber | Reprints free of charge. We encourage you to favor the online version and newsletter via www.fraunhofer.de/fhg/EN/press. This bulletin is also available in German as FORSCHUNG KOMPAKT.

Preventing dental implant infections

RESEARCH NEWS

11 | 2015 || Topic 1

Bacterial infection of a dental implant is a dreaded complication, as it carries with it a high risk of jawbone degeneration. Implanting an artificial dental root sets off a race between infectious pathogens and the body's own cellular defenses. If the bacteria win, they form a biological film over the titanium to protect themselves from antibiotics. Once the implant is colonized by germs, the result is an inflammatory reaction, which can result in bone atrophy.

To lower the risk of infection and improve the long-term effectiveness of the implant, researchers at the Fraunhofer Institute for Manufacturing Technology and Advanced Materials IFAM in Bremen have developed a new type of implant coating in cooperation with industry partners. The DentaPlas coating helps prevent the growth of bacteria, thus allowing the implant to properly take hold and thereby form a faster and more permanent bond with the jawbone. The trick to this lies in combining surface materials that feature physical as well as chemical properties. "We have given the DentaPlas coating a rough texture, which promotes cellular growth, in addition to combining it with a hydrophilic plasma polymer coating, which attracts moisture," says Dr. Ingo Grunwald, project manager at the IFAM. Researchers have integrated silver nanoparticles into the thin plasma polymer coating, which is up to just 100 nanometers thick. The silver nanoparticles dissolve over a period of several weeks, and during that time they continuously release small quantities of anti-microbial silver ions, which kill bacteria.

Three layers of protection

"The DentaPlas system consists of three layers, with two plasma polymer layers surrounding a center layer of silver. Within this structure a biocide reservoir is formed, and the outermost layer releases the ions. This is beneficial because it prevents direct contact between the tissue and the silver particles, which can be toxic when exposed," says developer Dr. Dirk Salz. Researchers can tailor the silver concentration as well as the thickness of the layers and their porosity. This allows the silver ions to penetrate the outermost plasma polymer layer over a set period of time deemed necessary to properly integrate the implant. When the silver reservoir is exhausted, no more silver ions are released, thus avoiding any long-term toxic effects.

In trials using finished implants and titanium test samples, the IFAM researchers demonstrated that the DentaPlas coating is not only anti-microbial but also fully biocompatible and sterilizable. The test samples were coated using a plasma polymerization facility at the IFAM in Bremen. Researchers confirmed the mechanical stability and robustness of the DentaPlas coating in trials using the lower jawbones of pigs taken from butcher shops. Here, they subjected the DentaPlas coated implants to the rigors of being screwed into place using the instruments found in modern dental practices.

The DentaPlas coating passed this stress test with flying colors. Project partner and Fraunhofer spinoff Bio Gate AG successfully transferred the processes of coating the test samples and titanium screws to its own production facilities. The medical technology company is also the manufacturer of the DentaPlas three-layer coating system.

A demonstration unit of the plasma polymer coating is currently available. Researchers will be presenting a dental implant featuring the DentaPlas coating at the MEDICA trade fair in Düsseldorf from November 16 -19 at the joint Fraunhofer booth (Hall 10, Booth G05).

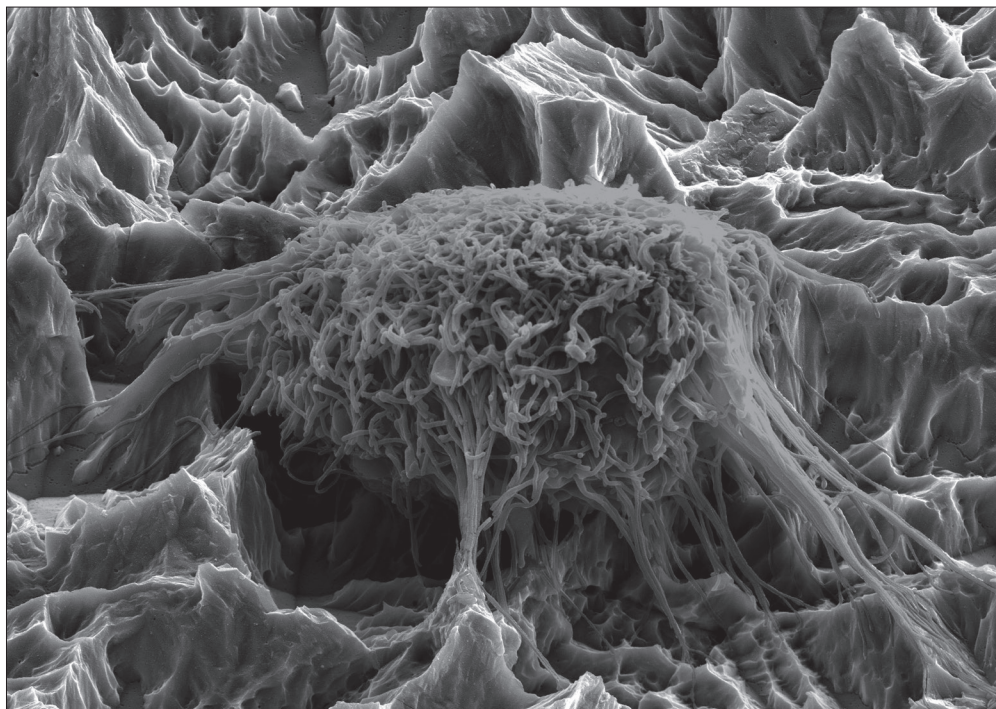

A scanning electron microscope image shows a properly grown cell on a dental implant.
(© Fraunhofer IFAM) | Picture in color and printing quality: www.fraunhofer.de/press

Economic LED recycling

RESEARCH NEWS

11 | 2015 || Topic 2

Modern illuminants are manufactured using a variety of materials. The housing is made of glass or plastic, the heat sink consists of ceramic or aluminum, and the resistors and cables contain copper. The most valuable materials are found within the LEDs themselves. They are indium and gallium inside the semiconductor diode and rare earths like europium or terbium in the phosphor. This makes it relatively expensive to manufacture the diodes, and the margins are small. "Right now recyclers are starting to receive LED products, but currently they are often simply stored as there is no suitable recycling process available yet. The main goal is to recover the valuable materials. It's only a matter of time until recyclers will have to start processing LEDs," says Jörg Zimmermann from the Fraunhofer Project Group for Materials Recycling and Resource Strategies IWKS in Alzenau and Hanau of the Fraunhofer Institute for Silicate Research ISC.

Separating components with the help of shock waves

Using the "electrohydraulic comminution" process, researchers break the LED lamps into their constituent parts without destroying the LEDs themselves. Shock waves created by electrical impulses in a water bath separate the individual components at their predetermined break points. The components can then be recycled individually. The researchers have adapted their experimental setup to retrofit lamps, which resemble traditional light bulbs or fluorescent tubes and can be used in the same standard sockets. "This method works in principle also for other sizes, for instance with LEDs from television sets or with automobile headlights, as well as with other electronic products," explains Zimmermann.

A prerequisite for an efficient recycling process is a neat separation of the components. "To efficiently separate and recycle all components of a LED lamp, an entirely different approach is necessary - one that produces large quantities of semiconductor and phosphor materials," says Zimmermann. If the entire retrofit is shredded, it is much more difficult to separate the resulting mixture of materials. Breaking LED lamps down to the component level also makes it easier to recover greater quantities of the materials contained in them. This is accomplished by collecting large quantities of similar components in which the concentration of individual elements is already higher. Zimmermann clarifies that this reprocessing is only profitable for recyclers and manufacturers, if it involves larger quantities.

"We're still testing whether the comminution process can be repeated until the desired materials have been separated," says Zimmermann. The researchers can adjust the parameters of the experimental setup like the type and quantity of the fluid, the container size, or the electric pulse voltage in such a way that separation occurs precisely at the specified break points. "In particular it is the number of pulses that determines how the components will separate," he says.

The electrohydraulic comminution process is currently being investigated in detail and improved further, also to gain access to other LED application areas. "Our research has demonstrated that mechanical separation is a viable method for improving the economics of LED lamp recycling," says Zimmermann.



LED-based lighting elements are currently available in a variety of different forms. To recycle them efficiently they must first be broken down into their constituent parts. When recycling the LED diodes themselves it is critical that they remain as intact as possible for collection. (© Fraunhofer ISC/IWKS) | Picture in color and printing quality: www.fraunhofer.de/press

Solar vehicle charging at home

The house of the future is environmentally friendly, energy efficient and smart. Its inhabitants can utilize rooftop-generated PV energy not only for household consumption but also to charge their personal electric vehicle. This scenario has already become reality for a collection of row houses built according to the “Passive House” standard in the German city of Fellbach in Baden-Württemberg. The group of new homes was upgraded as part of the “Fellbach ZeroPlus” project to include electromobility enhancements as well as a comprehensive energy management system. The initiative is sponsored by the German Federal Government’s “Electric Mobility Showcase” program.

Fast charging stations and home energy management

“The large photovoltaic systems on the rooftops of the houses provide more power than the inhabitants consume over the long term. Surplus power can be fed into the public grid as well as be used for charging the household electric vehicle,” explains Dominik Noeren, a scientist at the Fraunhofer Institute for Solar Energy Systems ISE in Freiburg. To efficiently incorporate electromobility enhancements into the daily routines of the households, Noeren and his team designed a 22 kW fast charging station as well as a home energy management system (HEMS) for five of the seven homes. The Java-based HEMS software runs on small computers known as embedded systems. The HEMS collects data from the various electricity meters in the house, including those for the photovoltaic system, the electric vehicle, the heat pump, and general household power. The system displays the various power flows and informs the homeowners about their current power consumption at any time of the day. “They can see how much power is coming from either the public grid or the household solar system, and they can see where it is going – to the heat pump, household appliances, or the electric vehicle,” says Noeren.

Furthermore, the HEMS also forecasts solar intensity over the next 20 hours or so and provides users with information on how much solar power is available. An adaptive algorithm also computes anticipated household power loads for each quarter hour. Using this data, it is possible to determine how much PV power is available for the electric vehicle at any given time. “Electricity from the PV first goes to the house, and power that is not consumed there is stored in the electric vehicle battery. If there is still any electricity left over after that, it is fed into the public electricity grid,” explains Noeren.

During two years of field testing, an Android application was created using feedback from the homeowners. The HEMS app provides a visualization of all processes and electricity flows in real time, and gives solar intensity forecast readouts in graphical and numerical form. An adaptive algorithm works to optimize the use of the power generated by each household. Through the app, users can control the charging station as

well as view the battery charge level and charging times of the electric vehicle. “These parameters are necessary in order to intelligently charge the electric vehicle,” says Noeren.

To create an ideal charging itinerary, the system must know the vehicle’s current battery charge level as well as its next planned departure time. The energy management system uses this information together with weather and consumption forecasts to estimate the flows through the household power network. It calculates how much electricity must be topped up, as well as which time periods are ideal for recharging the vehicle using the greatest possible proportion of household-produced solar energy.

“It is more cost effective to consume the self-generated solar electricity than to feed it into the public electricity grid,” says Noeren. The HEMS system helps consumers use data on driving times, solar intensity forecasts and current household energy consumption to synchronize electric vehicle charging times with rooftop energy production, so they can maximize the proportion of household-produced energy they use. This not only helps homeowners lower their costs, but it also goes a step closer towards realizing the ideal of low-CO₂ homes and personal mobility. Maximizing the proportion of household-produced energy consumed helps unburden the public power grid while reducing household feed-in peaks to the grid.

The HEMS system is based on the Fraunhofer openMUC framework, which supports a wide variety of meters and devices. It offers modular expandability for integrating devices such as wireless Bluetooth or WLAN power outlets that can remotely activate and deactivate household appliances, or for integrating high-consumption items such as heat pumps. Two of the five households in the “Fellbach ZeroPlus” project have been successfully using a car-sharing variant of the system as part of a field test since mid-2014.



An electric vehicle is charged with photovoltaic power from the roof of the house using a charging station. (© Fraunhofer ISE) | Picture in color and printing quality: www.fraunhofer.de/press

The navigation app for buildings

RESEARCH NEWS

11 | 2015 || Topic 4

Large public building complexes, such as exhibition halls, airports, shopping centers or museums, as well as hospitals and public authority buildings are sometimes like a maze. Arrows, maps and signs are supposed to make it clearer. But right when you enter the building for the first time, it is often very laborious and complicated to follow them through the maze of corridors, hallways, rooms and floors. Classic GPS-based navigation apps do not work in enclosed spaces, because the satellite signals are sometimes significantly disrupted by walls and ceilings.

Software evaluates WLAN signals

Researchers at the Fraunhofer Institute for Photonic Microsystems IPMS in Dresden, Germany have found a way to use smartphones for navigation inside buildings too. For this they rely on WLAN: With local radio networks, the researchers locate smartphones indoor to within about two meters. To determine the position, the software evaluates the signal strength of the WLAN spots. The app, which was originally developed for use in hospitals, is based on the Android mobile phone operating system.

When starting the app, different targets can be selected – for example, examination rooms, patient rooms, cafeterias and restrooms or mobile inventory, such as beds and wheelchairs. As with navigation devices in cars, the user sees the building plan in a two-dimensional bird's-eye view. The target and current position are marked with dots and the shortest route is shown on the map. If the user moves, so does his position point. If the destination is outside the screen or on a different floor, arrows show the way. The hospital provides the material for the desired maps. Emergency evacuation plans can often be used as a template. "We can bring any large map sharply and without any annoying delays onto every screen," says Christian Scheibner from the Department of Wireless Microsystems of the IPMS. The app receives all the necessary data from the user's server.

Thanks to open interfaces, the positioning and navigation algorithms as well as the graphical representations can be installed simply and straightforwardly in customers' applications. In the apps of trade fairs organizers, for example, which often lack maps, route planning or position determination. "Hospitals have caught up considerably in terms of wireless hot spots in recent years. For example, there are more and more medical devices which are equipped with WLAN and which can be used for indoor navigation" says the hardware and software developer Scheibner.

The software works in all indoor areas where WLAN is available. The navigation destinations can be linked with other information. As a result, a user in a shopping mall, for example, will find his way directly and quickly to the rack with special deals.

A demo system of the app is running successfully at the IPMS. "Interested parties can try it on site at the Institute at any time" says Scheibner. The technology was developed on behalf of an infrastructure outfitter for hospitals. They are being presented at the MEDICA international trade fair in Dusseldorf from November 16 to 19, 2015.



Find your way around more easily with a navigation app, even inside buildings: For this, Fraunhofer researchers use the WLAN signals indoors. (© Fraunhofer IPMS) | Picture in color and printing quality: www.fraunhofer.de/press

The helping hand in the operation room

RESEARCH NEWS

11 | 2015 || Topic 5

In the future, surgical assistants could be relieved by surgeons, to devote their time instead to their own patients. This is expected to be made possible by a device which has been developed by researchers from the project group for automation in medicine and biotechnology at the Fraunhofer Institute for Manufacturing Engineering and Automation IPA in Mannheim, Germany – together with their colleagues from the surgical clinic of the University Hospital of Mannheim. The project was funded by the Baden-Württemberg Foundation. “It can take on smaller tasks, such as moving and holding tools or even retracting something,” explains Marc Arends, scientist of the IPA project group. The device is reminiscent of a robot arm. The researchers have designed it so that it can hold standard instruments – like those which are already in use in the operating room. One example are endoscopes, which take pictures inside the patient’s body and transmit outwardly: Once the doctor introduces such an endoscope through a tiny incision in the patient’s body, the system takes over: It holds the tool and can adjust the position of the endoscope under the direction of the doctor. The device ensures that damaging the incision point, i.e. the point at which the endoscope enters the body, is mechanically impossible.

Controlled by gestures

The surgeon mainly controls the mechanical assistant through gestures. To this end, on a display screen, he sees a virtual representation of his hand as well as a small dot, indicating the position of the tool. When he moves his hand, the virtual display on the monitor does likewise. If the doctor “grabs” at the point, he can move it – and position the tool accordingly. The big advantage: he does not have to take off his gloves or touch anything. “As for sterility, we are on the safe side,” says Arends. Special gloves are not necessary.

The researchers are addressing the situation of the surgeon himself holding instruments, making gesture control difficult in the short term: They are currently working on being able to control the system via speech. If the doctor has informed the surgical assistants in advance which movement he intends to perform on the command “retract”, for example, the mechanical hand will also respond to spoken commands in the future.

So that the physician can adjust the manipulator as accurately as possible, his movements are scalable. While the endoscope has to be moved to the right place in the beginning (i.e. the device executes larger movements), smaller movements are required during the subsequent fine adjustment.

The demonstrator has already been completed. The researchers are going to introduce it at the MEDICA trade fair in Dusseldorf from November 16th to 19th (Hall 10, Booth

G05). The user interface via which the surgical assistant can be controlled by gestures will also be on display at the trade fair. In addition, the first trials in which doctors are testing the metal hand have already begun. During this process, the questions include: How effective is the team consisting of man and machine? What needs to be improved? The results of the trial series influence the further development of the helping hand.

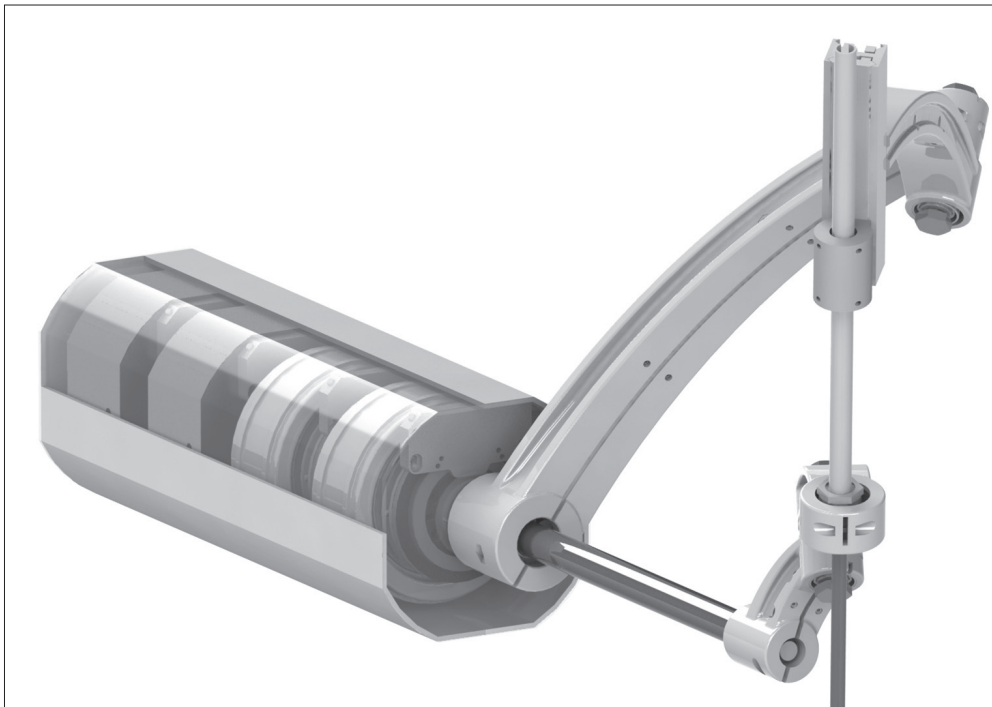

The helping hand can take over smaller activities, such as holding clamps in the operating room.
(© Fraunhofer IPA) | Picture in color and printing quality: www.fraunhofer.de/press

Simulating technical textiles perfectly

RESEARCH NEWS

11 | 2015 || Topic 6

The new T-shirt is nice and soft, it is comfortable to wear, and the fabric falls loosely. This usually meets the requirements in the field of fashion. The situation is different in the case of technical textiles. They have to meet different requirements. Compression bandages, for example, should put pressure on the human tissue, therefore the stretchability of the material has to be right. Materials for protective jackets need to have a certain bending stiffness: If something hits them, the material should protect the wearer and not yield. Textiles for car seats have to be durable, especially at the edges. Manufacturers of these products have two determining factors with which they can define the properties: the yarns, as well as the structure via which the individual yarns are interconnected – such as special weave patterns or mesh variations.

The mechanical properties of the yarns can be identified relatively easily: With a device into which they are clamped. It pulls the fiber and measures how much force is required to stretch it by a predetermined value. It is harder to comment on the properties of the fabric, though: The fabric has to be produced and then tested. However, this can naturally only be done with samples. It would be too costly to produce all conceivable designs with the various yarns.

Integrated simulation instead of samples

The Fraunhofer Institute for Industrial Mathematics ITWM in Kaiserslautern, Germany has developed a simpler and also more insightful method to improve the properties of textiles. “We simulate the behavior of the materials”, says Dr. Julia Orlik, scientist at the ITWM. “In that way, we are able to accurately predict which properties the fabrics have depending on the yarn and structure”. The benefits: With the simulation, the researchers can examine all of the conceivable variants of patterns and yarns and analyze which one is optimal for the desired application. All without having to produce the individual textiles. For the first time, they can even simulate the contact between the yarns. How well do the individual threads slide over each other? And how does this in turn affect the entire fabric?

A starting point for the simulation are the parameters that the scientists receive from the manufacturers. These relate mainly to the yarns. In terms of contact properties, the question is more difficult: Few manufacturers can determine these parameters. Therefore, the researchers take measurements from selected real pieces of fabric, comparing them to the simulations and adjusting the parameters until the results of the simulation and the experiment match.

The researchers do not only analyze individually selected structures; they also change them gradually. “Take the shape of a single mesh, for example. It resembles a Greek letter Ω somewhat. Now, you can make this Ω longer and narrower, or shorter and

wider. We change the mesh shape continuously and see what effect that has on the entire fabric," says Orlik. "In short: We compute the best configuration".

In addition, the researchers are investigating the yarns: How do the properties of the fabric change if, say, more stretchable yarn is used? The parameters are provided by the manufacturers. If a manufacturer has already decided upon a certain yarn, for example, the researchers look for the best structure for this yarn.

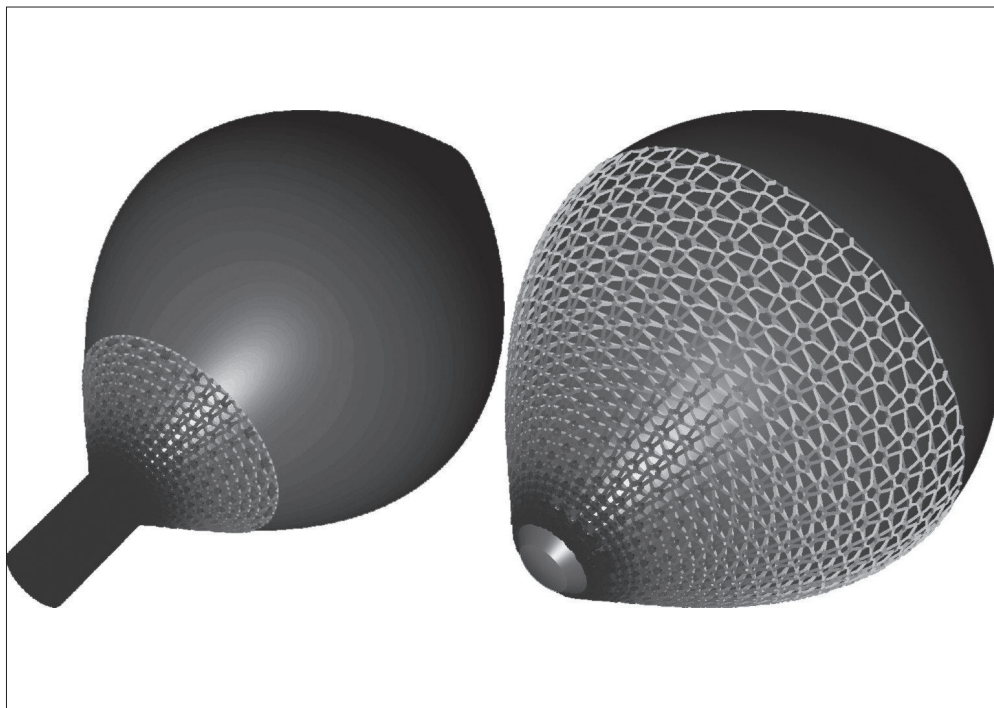

A technical fabric is stretched onto a sample body (left). The simulation analyzes how the fabric stretches and slides over the body surface (right). (© Fraunhofer ITWM) | Picture in color and printing quality: www.fraunhofer.de/press